

## Set montaggio antifurto - 96681361AA

### Anti-theft system assembly kit - 96681361AA

#### Simbologia

Per una lettura rapida e razionale sono stati impiegati simboli che evidenziano situazioni di massima attenzione, consigli pratici o semplici informazioni. Prestare molta attenzione al significato dei simboli, in quanto la loro funzione è quella di non dovere ripetere concetti tecnici o avvertenze di sicurezza. Sono da considerare, quindi, dei veri e propri "promemoria". Consultare questa pagina ogni volta che sorgessero dubbi sul loro significato.



#### Attenzione

La non osservanza delle istruzioni riportate può creare una situazione di pericolo e causare gravi lesioni personali e anche la morte.



#### Importante

Indica la possibilità di arrecare danno al veicolo e/o ai suoi componenti se le istruzioni riportate non vengono eseguite.



#### Note

Fornisce utili informazioni sull'operazione in corso.

#### Riferimenti

I particolari evidenziati in grigio e riferimento numerico (Es. ①) rappresentano l'accessorio da installare e gli eventuali componenti di montaggio forniti a set.

I particolari con riferimento alfabetico (Es. Ⓐ) rappresentano i componenti originali presenti sul motoveicolo.

Tutte le indicazioni destro o sinistro si riferiscono al senso di marcia del motociclo.

#### Avvertenze generali



#### Attenzione

Le operazioni riportate nelle pagine seguenti devono essere eseguite da un tecnico specializzato o da un'officina autorizzata Ducati.



#### Attenzione

Le operazioni riportate nelle pagine seguenti se non eseguite a regola d'arte possono pregiudicare la sicurezza del pilota.



#### Note

Documentazione necessaria per eseguire il montaggio del Set è il Manuale Officina, relativo al modello di moto in vostro possesso.



#### Note

Nel caso fosse necessaria la sostituzione di un componente del set consultare la tavola ricambi allegata.

#### Symbols

To allow quick and easy consultation, this manual uses graphic symbols to highlight situations in which maximum care is required, as well as practical advice or information. Pay attention to the meaning of the symbols since they serve to avoid repeating technical concepts or safety warnings throughout the text. The symbols should therefore be seen as real "reminders". Please refer to this page whenever in doubt as to their meaning.



#### Warning

Failure to comply with these instructions may put you at risk and lead to severe injury or even death.



#### Important

Failure to comply with these instructions may lead to serious damage to the motorcycle and/or its components.



#### Notes

It provides useful information about the current operation.

#### References

The parts highlighted in grey and with a reference number (e.g. ①) represent the accessory to be installed and any assembly components supplied with the set.

The parts with alphabetic reference (e.g. Ⓐ) represent the original components present on the motorcycle.

All left and right indications are referred to the motorcycle direction of travel (forward riding position).

#### General notes



#### Warning

The operations listed in the following pages must be carried out by a specialised technician or by a Ducati authorised service centre.



#### Warning

Carefully perform the operations on the following pages since they might negatively affect rider safety.



#### Notes

The Workshop Manual specific for your bike model is the documentation required to assemble the set.



#### Notes

If a set component needs to be replaced, refer to the attached spare parts table.



#### Warning

Operating, servicing and maintaining a passenger vehicle or off-highway motor vehicle can expose you to chemicals including engine exhaust, carbon monoxide, phthalates, and lead, which are known to the State of California to cause cancer and birth defects or other reproductive harm. To minimize exposure, avoid breathing exhaust, do not idle the engine except as necessary, service your vehicle in a well-ventilated area and wear gloves or wash your hands frequently when servicing your vehicle. For more information go to [www.P65Warnings.ca.gov/passenger-vehicle](http://www.P65Warnings.ca.gov/passenger-vehicle).

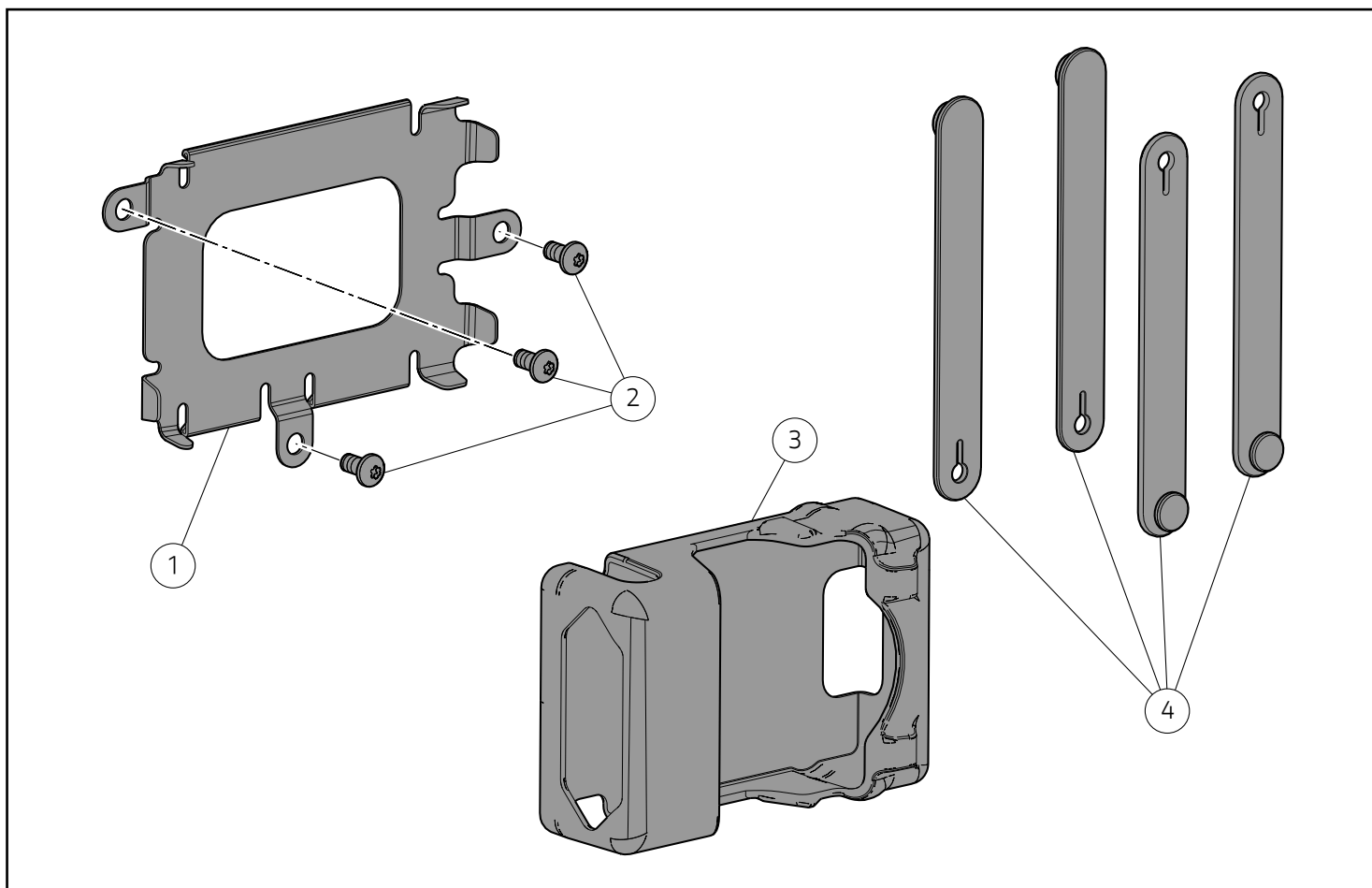

### ● Importante

I componenti del set possono essere soggetti ad aggiornamenti; consultare il DCS (Dealer Communication System) per avere informazioni sempre aggiornate.

### ● Importante

Il presente set montaggio antifurto deve essere abbinato al set antifurto, composto da centralina e telecomandi, adeguato al modello di motoveicolo in possesso.

### ● Important

Set components may be subject to upgrades; refer to the DCS (Dealer Communication System) for updated information.

### ● Important

This anti-theft system assembly set must be combined with the anti-theft system set, consisting of control unit and remote controls, suitable for the concerned bike.

Pos.	Denominazione	Name
1	Staffa	Bracket
2	Vite AF D4x8	Self-tapping screw D4x8
3	Tampone supporto antifurto	Anti-theft system support buffer
4	Fascetta in gomma L=82 mm	Rubber tie L=82 mm

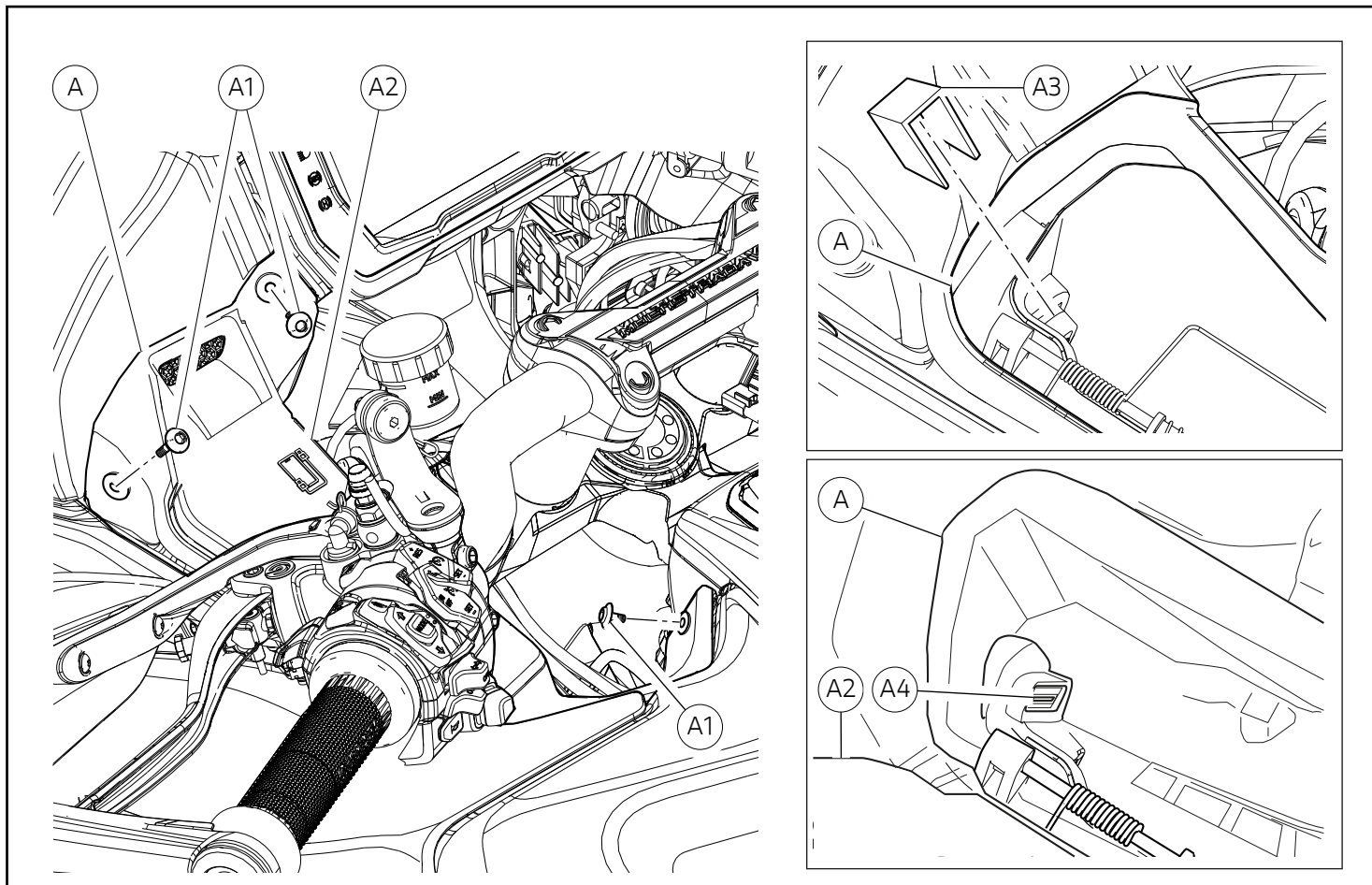

## Smontaggio componenti originali

### Smontaggio vano smartphone



#### Note

Per una migliore visualizzazione del vano smartphone (A) e dei componenti su cui operare, nell'immagine è stato rimosso il manubrio.

Svitare le n.3 viti (A1) di fissaggio. Premere sullo sportellino vano (A2) per aprirlo. Sfilare superiormente il fermaglio (A3) della presa USB (A4) e rimuoverla dal vano (A).

## Removing the original components

### Removing the smartphone compartment



#### Notes

For a better view of the smartphone compartment (A) and components to work on, the handlebar has been removed from the image.

Loosen the no.3 retaining screws (A1). Press on compartment flap (A2) to open it. Slide out clip (A3) of USB socket (A4) from above and remove it from compartment (A).

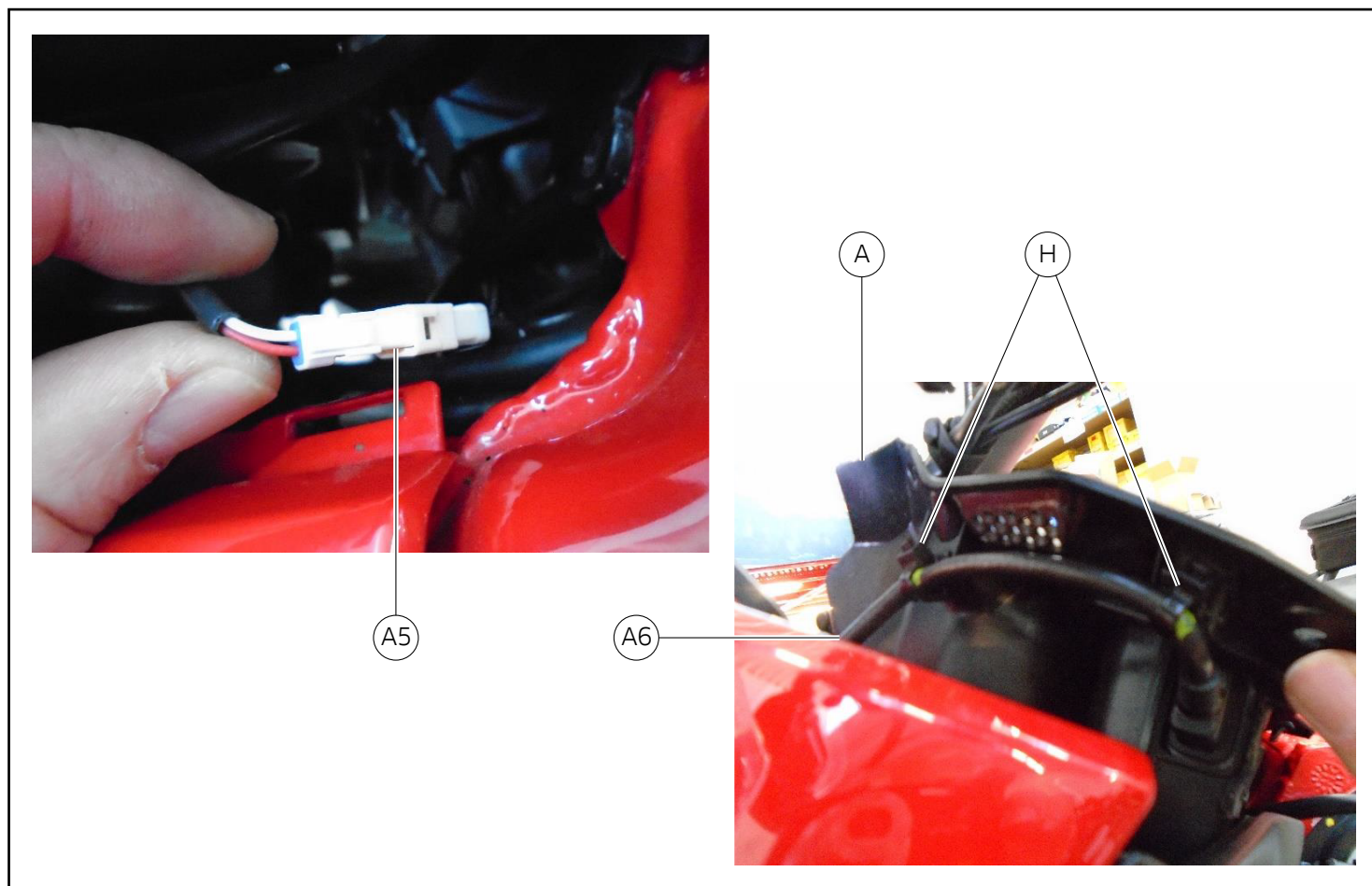

Scollegare il connettore (A5) alimentazione ventola vano.

Sollevando il vano (A), riuuovere le n.2 fascette in nylon (H) del cavo (A6) presa USB.

Estrarre verso l'alto il vano porta smartphone (A).

Disconnect compartment fan power supply connector (A5).

Lift compartment (A) and remove the no.2 nylon ties (H) of USB socket cable (A6).

Remove smartphone holder compartment (A) by pulling it upwards.

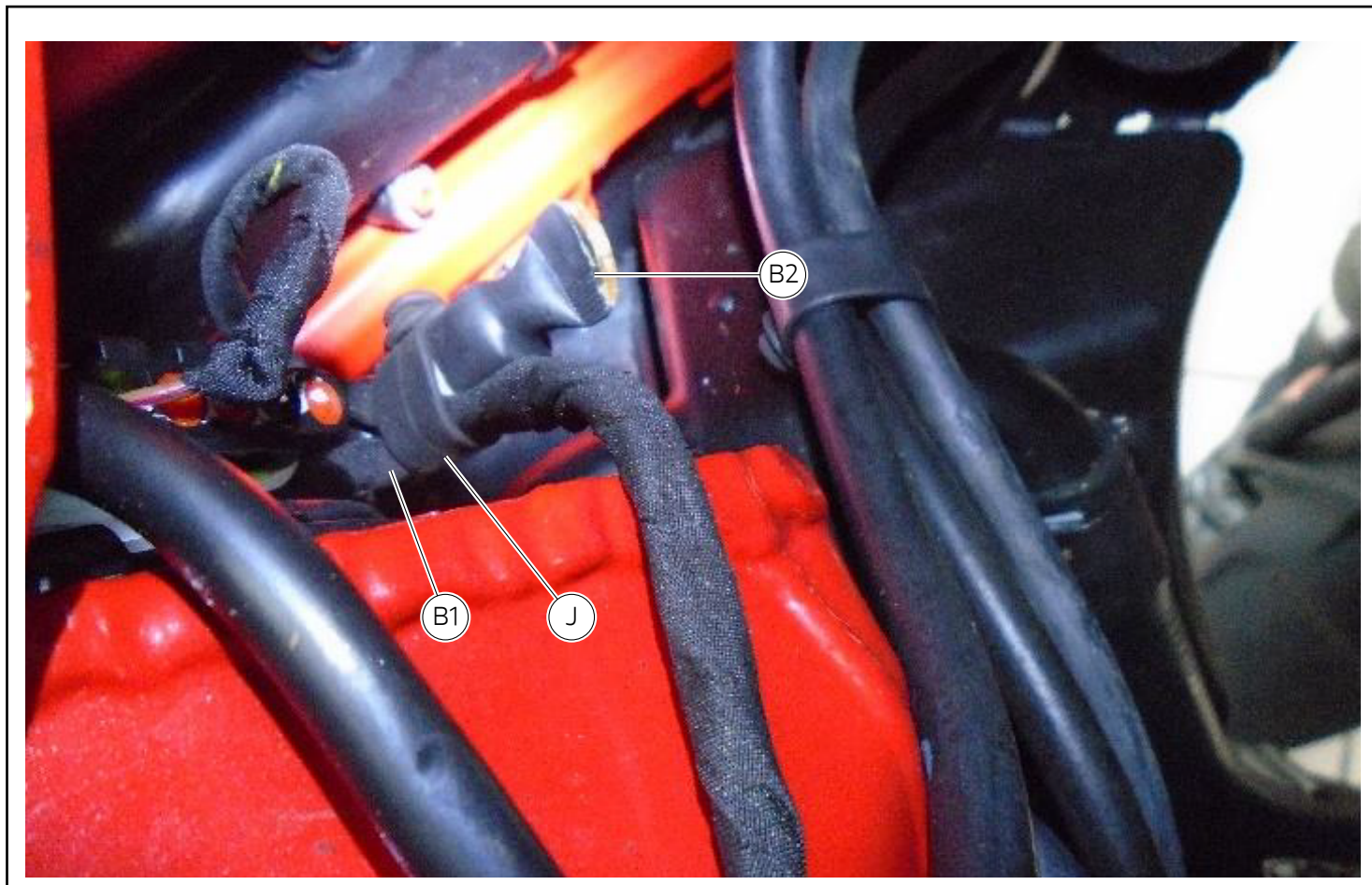

Liberare il cavo di alimentazione (B1) della centralina antifurto dal fissaggio tramite n.1 fascetta in gomma (J) e dal tappo (B2).

Release power cable (B1) of anti-theft system control unit from fastening through no.1 rubber tie (J) and plug (B2).

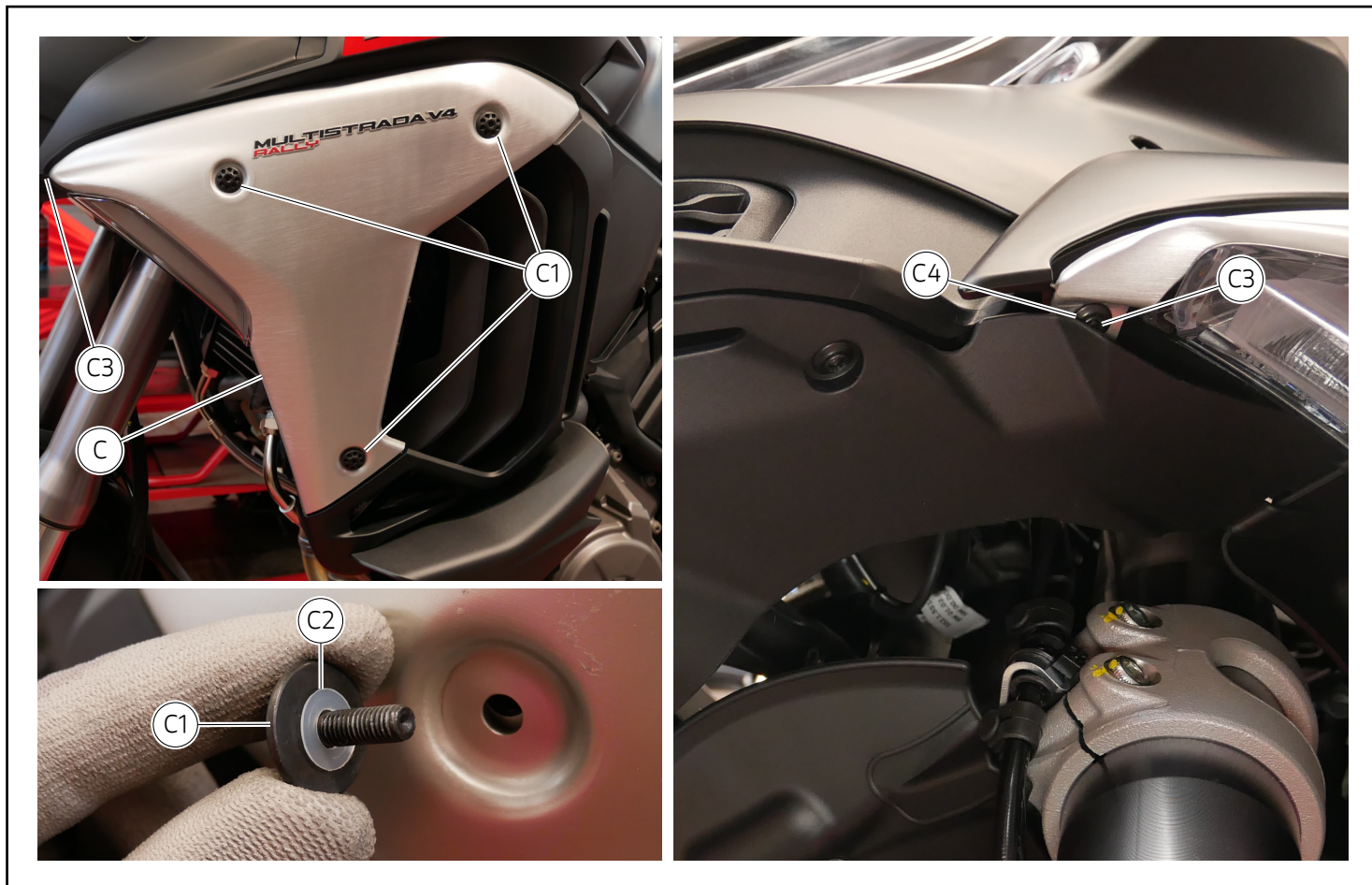

### Smontaggio ala sinistra

Operando sul lato sinistro, svitare le n.3 viti (C1) e recuperare le n.3 rosette inferiori (C2). Svitare la vite (C3) e recuperare la rosetta (C4). Rimuovere la carena sinistra (C) sfilandola.

### Removing the LH cowling

Working on LH side, loosen no.3 screws (C1) and collect no.3 lower washers (C2). Loosen screw (C3) and collect washer (C4). Remove the LH fairing (C) by sliding it out.



### Smontaggio struttura ala sinistra

Rimuovere le n.3 fascette in nylon (D1). Svitare le n.2 viti (D2) di fissaggio struttura ala sinistra (D).

### Removing the LH cowling structure

Remove no.3 nylon ties (D1). Loosen no.2 screws (D2) fastening LH cowling structure (D).

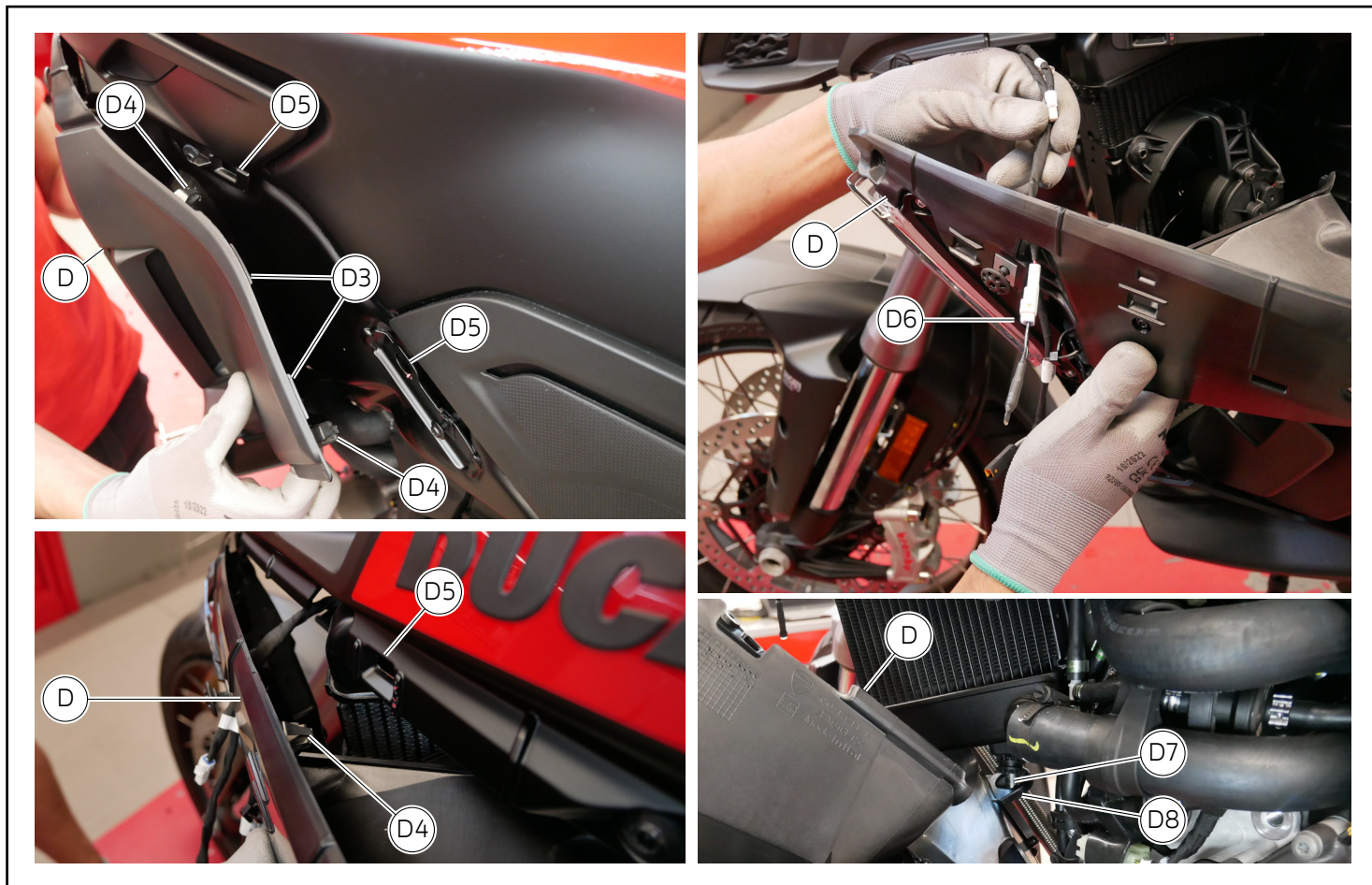

Sfilare la struttura ala sinistra (D) sfilando le n.2 alette (D3). Liberare gli agganci (D4) dalle asole (D5). Scalzare i cavi (D6) e sfilare l'asola (D8) dal perno (D7) del radiatore.

Slide out LH cowling structure (D) by sliding out no.2 tabs (D3). Release hooks (D4) from slots (D5). Release cables (D6) and slide slot (D8) out of radiator pin (D7).





### Smontaggio cover serbatoio sinistra

Svitare le n.4 viti (E1) di fissaggio cover serbatoio sinistra (E) e recuperare le n.4 rosette inferiori (E2). Sfilare la cover (E) liberando le asole (E3) dal serbatoio. Sfilare l'aletta (E4) dalla sede (E5).

### Removing the fuel tank LH cover

Loosen no.4 screws (E1) securing LH tank cover (E) and collect no.4 lower washers (E2). Slide out cover (E) to release slots (E3) from tank. Remove tab (E4) from seat (E5).

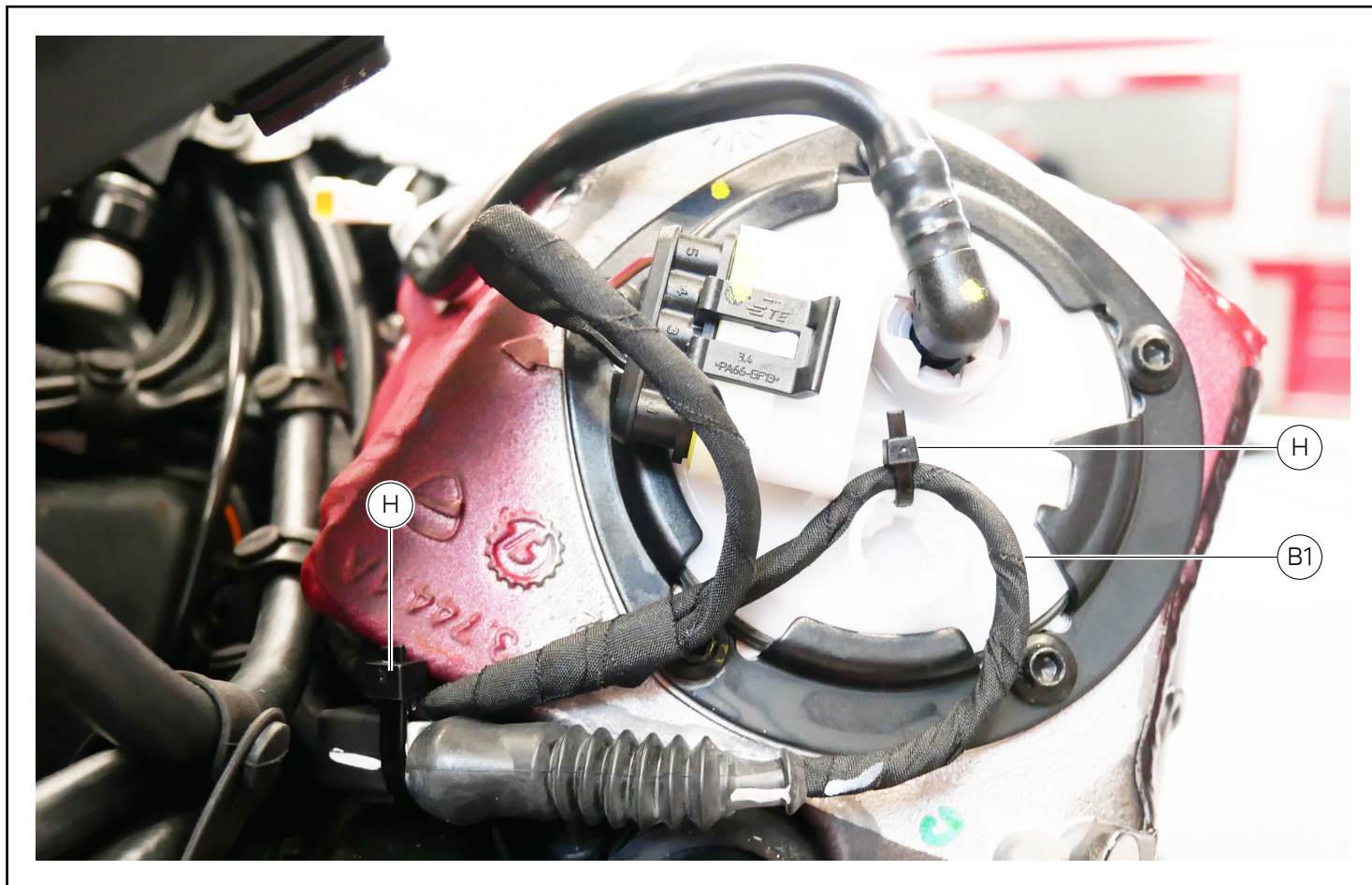

Rimuovere le n.2 fascette in nylon (H) e liberare il cavo alimentazione (B1) centralina antifurto.

Remove no.2 nylon ties (H) and free the power cable (B1) of control unit anti-theft system.

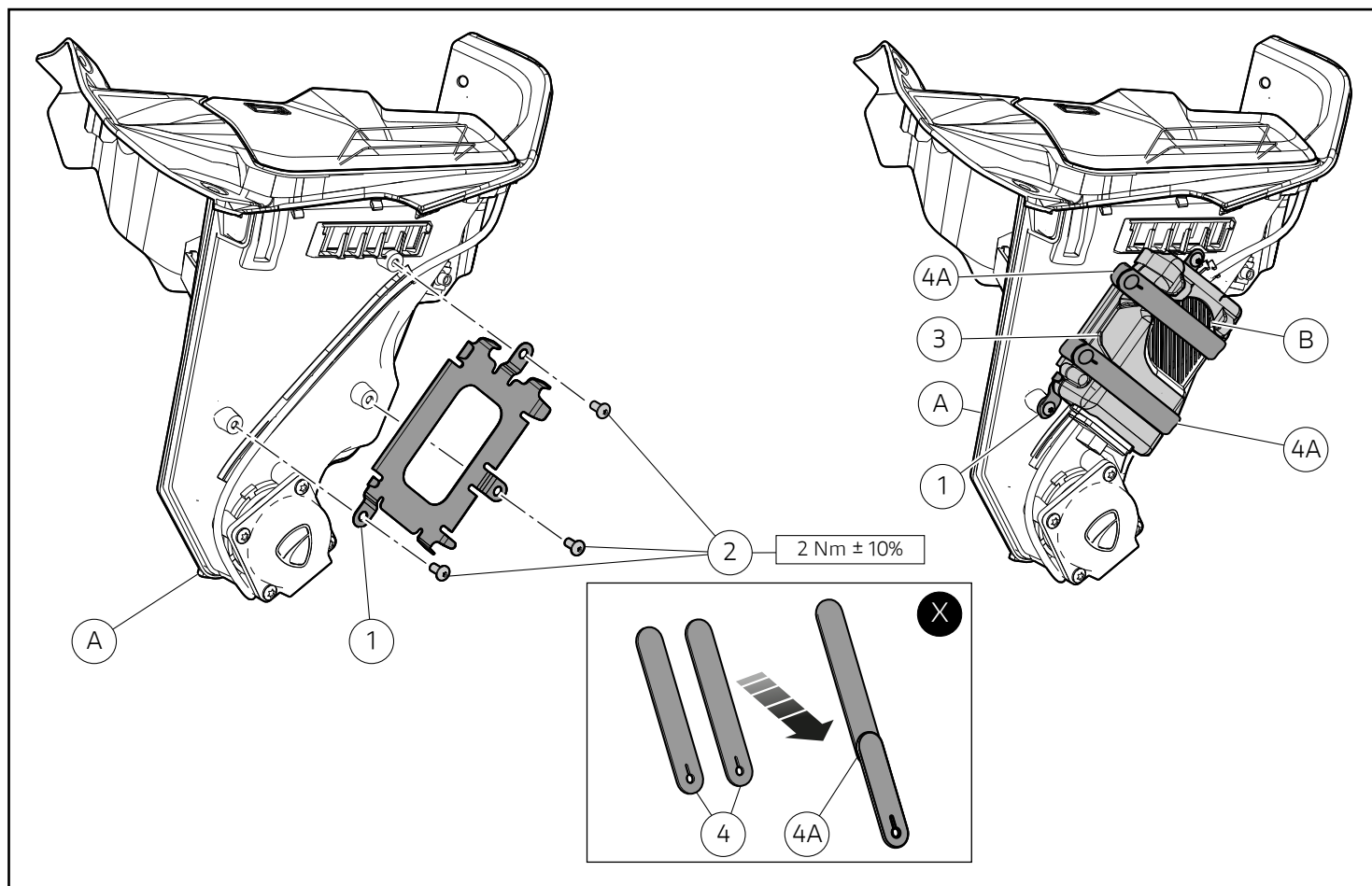

## Montaggio componenti set

### ● Importante

Verificare, prima del montaggio, che tutti i componenti risultino puliti e in perfetto stato. Adottare tutte le precauzioni necessarie per evitare di danneggiare qualsiasi parte nella quale ci si trova ad operare.

### Premontaggio centralina antifurto

Posizionare la staffa (1) sul vano smartphone (A) e serrare le n.3 viti (2) alla coppia indicata. Dopo aver inserito la centralina (B) nel tampone (3), posizionarla sulla staffa (1). Vincolare la centralina antifurto (B) alla staffa (1) tramite le n.2 fascette in gomma (4A), ottenute unendo n.2 fascette (4), come indicato in figura (X).

## Assembling the set components

### ● Important

Before assembly, make sure that all parts are clean and in perfect conditions. Take all the necessary measures to avoid damaging any part you are working on.

### Anti-theft system control unit pre-assembly

Place bracket (1) on smartphone compartment (A) and tighten no.3 screws (2) to the specified torque. After inserting control unit (B) in buffer (3), place it on bracket (1). Tie the anti-theft system control unit (B) to the bracket (1) using the no.2 rubber ties (4A) made by joining no.2 ties (4), as shown in the figure (X).

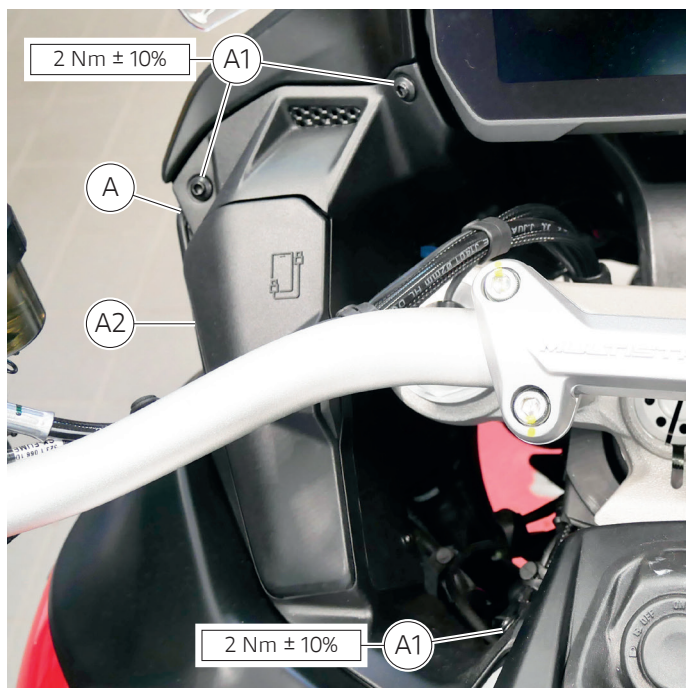
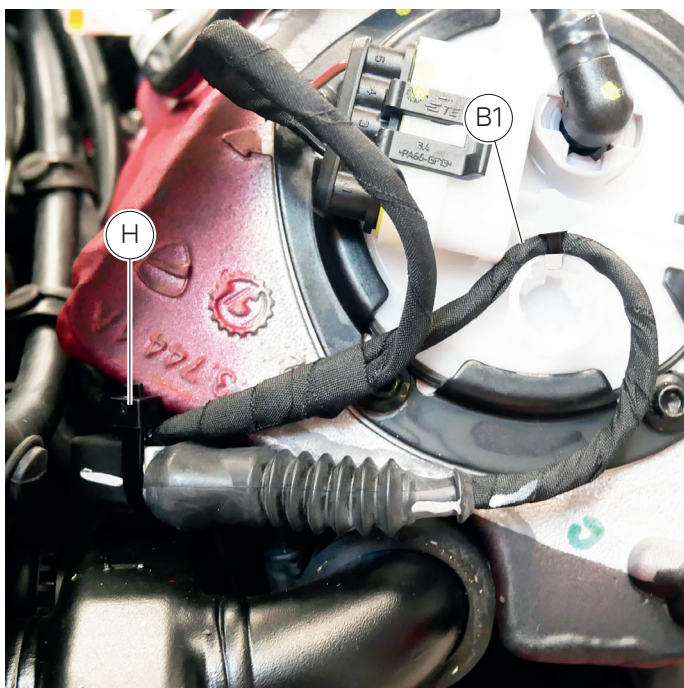
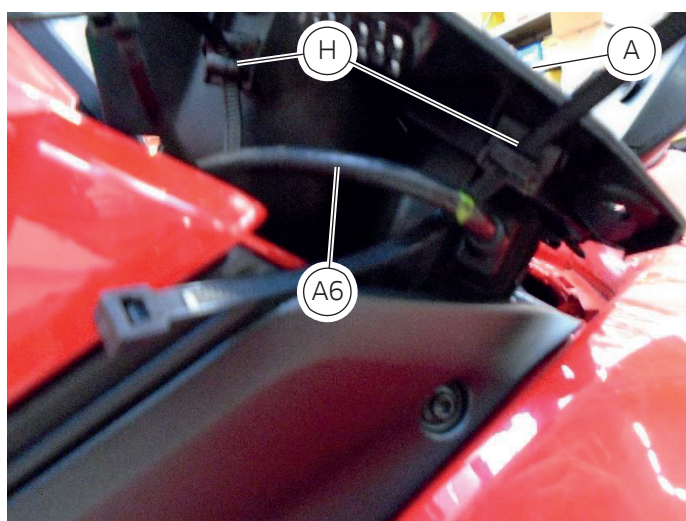
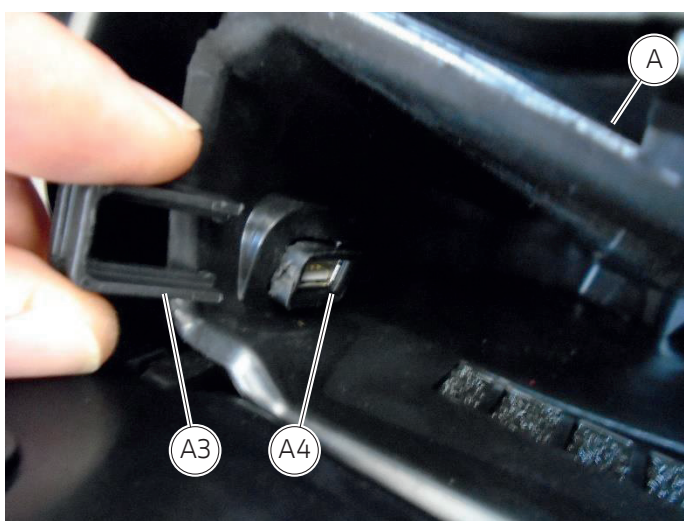
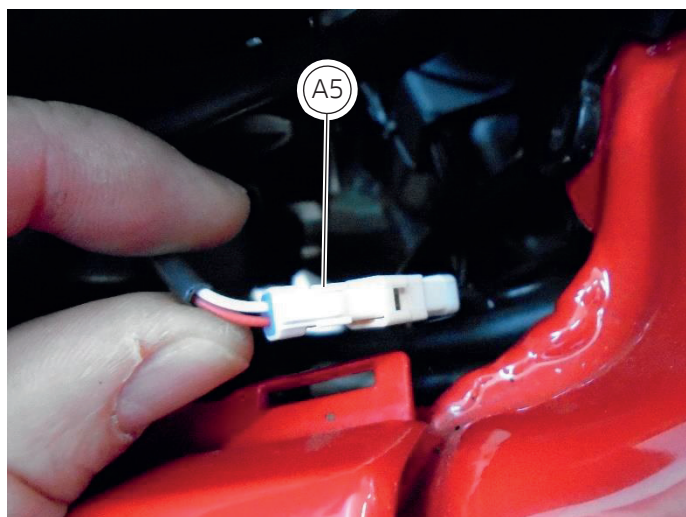
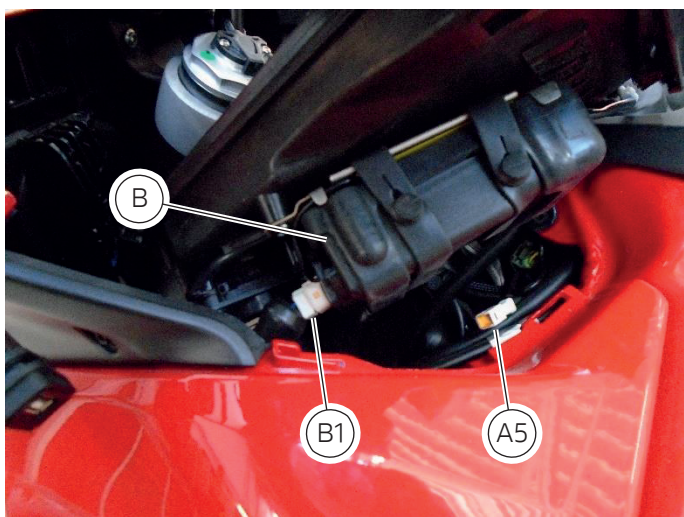

### **Importante**

Prestare molta attenzione al posizionamento dei cablaggi e delle nuove fascettature, al fine di non tensionare i cablaggi in maniera eccessiva.

### **Importante**

Prestare molta attenzione al posizionamento dei cablaggi rispetto al vano smartphone, alla centralina e ai tubi canister, affinché non si arrechino danni al funzionamento degli impianti interessati.

Posizionare l'assieme vano smartphone (A) all'interno del veicolo. Connettere l'alimentazione (B1) della centralina (B) e l'alimentazione (A5) della ventola vano.

Collocare la presa USB (A4) in sede e applicare il fermaglio (A3). Fissare il cavo USB (A6) tramite n.1 nuova fascetta in nylon (H).

### **Importante**

Montare solo la fascetta in nylon indicata e non ripristinare la seconda al GAC.

Calzare l'assieme vano smartphone (A), sino a portarlo in battuta e serrare le n.3 viti (A1) alla coppia indicata. Chiudere lo sportellino vano (A2).

### **Important**

Pay attention when positioning wirings and new ties, in order not to excessively tension the wirings.

### **Important**

Pay attention to the positioning of wirings with respect to the smartphone compartment, control unit and canister hoses, so as not to damage the operation of the systems concerned.

Position smartphone compartment assembly (A) inside the vehicle. Connect power supply (B1) of control unit (B) and power supply (A5) of compartment fan.

Place USB socket (A4) in its seat and apply clip (A3). Secure USB cable (A6) using no.1 new nylon tie (H).

### **Important**

Only fit the indicated nylon tie and do not restore the second GAC tie.

Fit smartphone compartment assembly (A) fully home and tighten no.3 screws (A1) to the specified torque. Close compartment flap (A2).

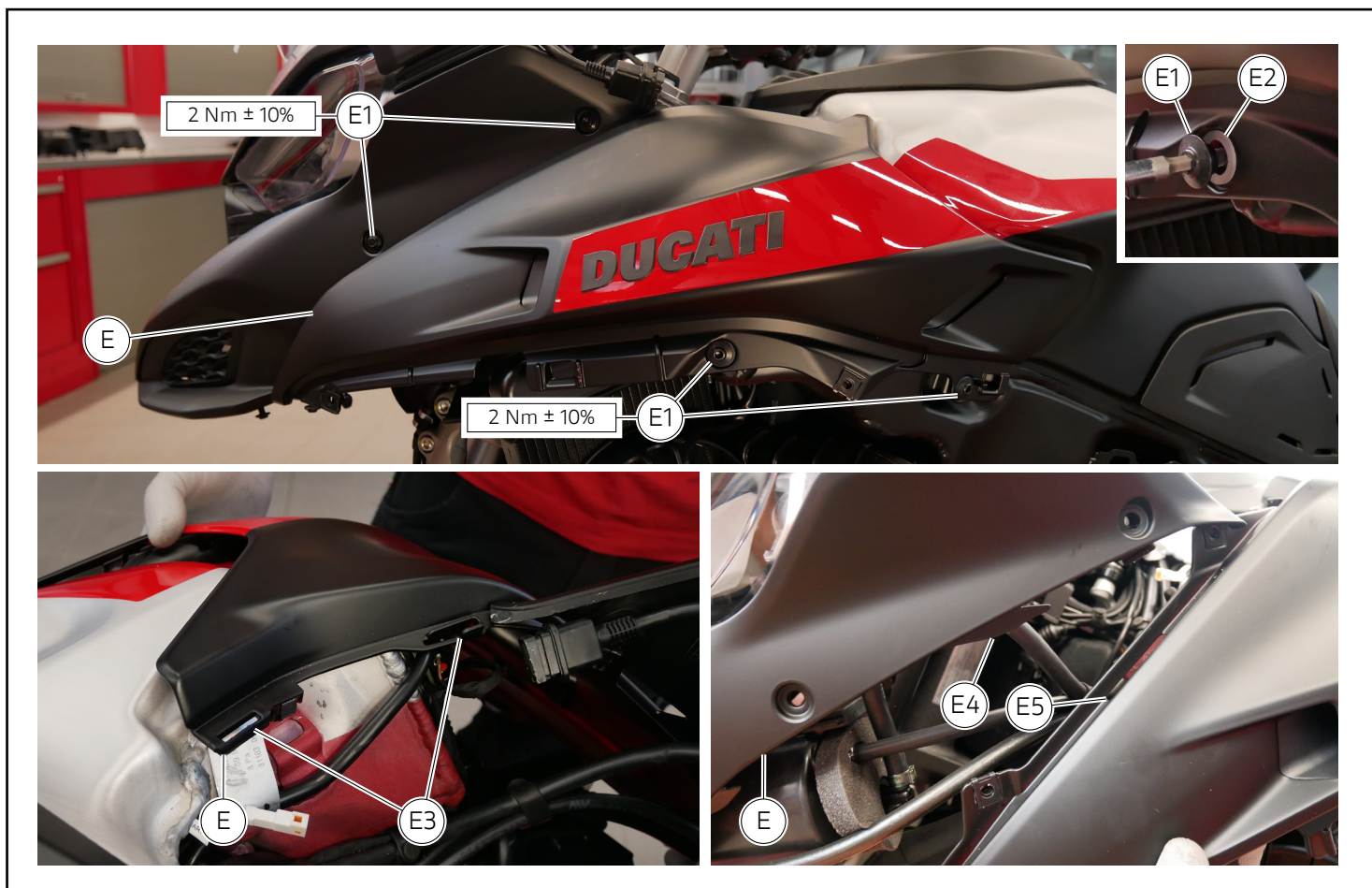

### Rimontaggio componenti originali

#### Rimontaggio cover serbatoio sinistra

Posizionare la cover (E) vincolandola al serbatoio tramite le n.2 asole (E3). Inserire l'aletta (E4) nell'asola (E5). Serrare alla coppia indicata le n.4 viti (E1) di fissaggio cover serbatoio, dopo aver posizionato inferiormente, le relative n.4 rosette (E2).

### Refitting the original components

#### Refitting the fuel tank LH cover

Position cover (E) and secure it to the tank using the no.2 slots (E3). Insert tab (E4) into the slot (E5). Tighten no.4 screws (E1) securing tank cover to the specified torque, after positioning the relevant no.4 washers (E2) below.

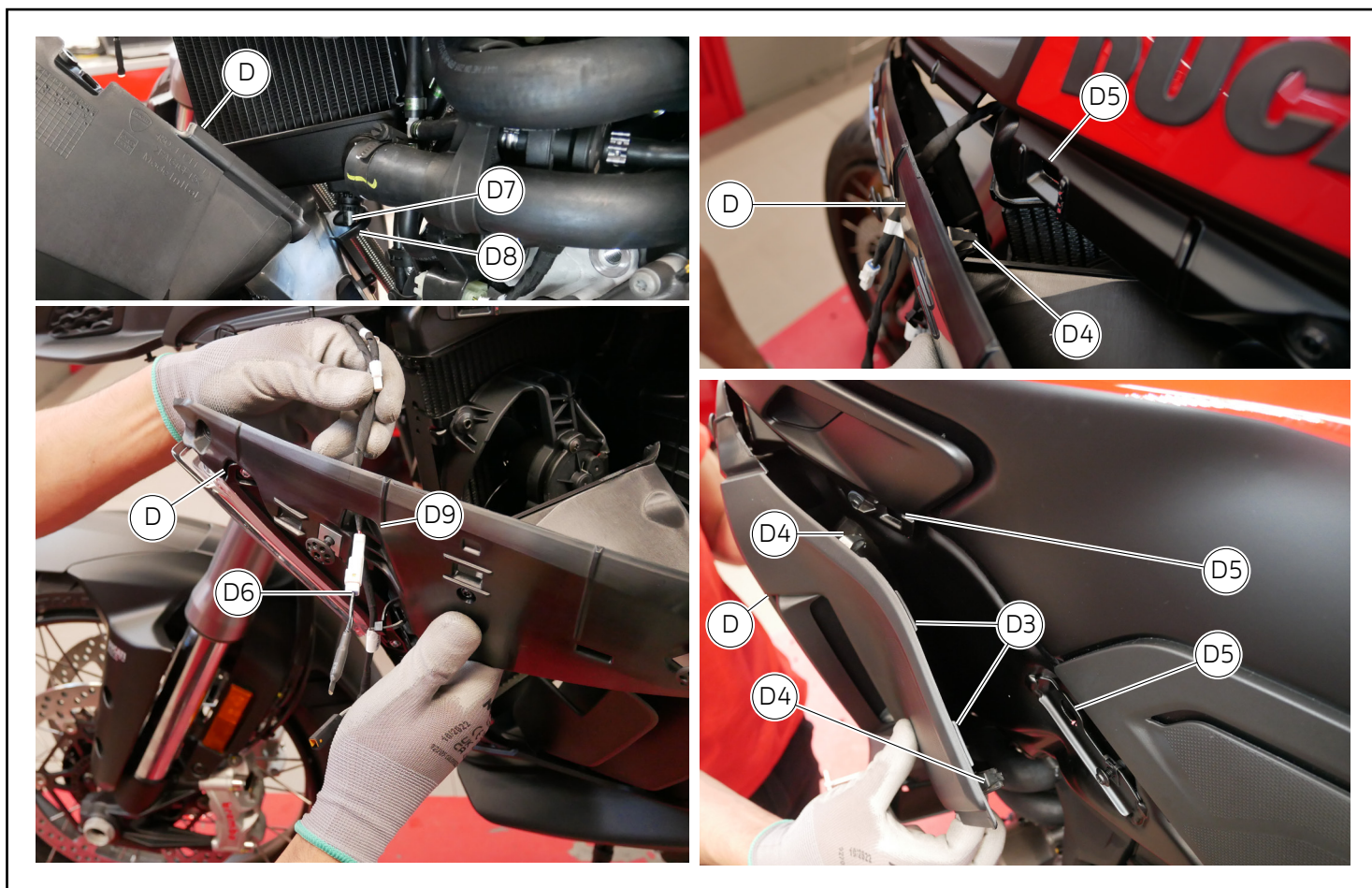

### Rimontaggio struttura ala sinistra

Posizionare la struttura ala sinistra (D) inserendola nel perno (D7) del radiatore, tramite l'asola (D8).

Permettere il passaggio del cablaggio (D6) attraverso l'asola (D9).

Vincolare i n.2 agganci (D4) nelle asole (D5).

Inserire le n.2 alette (D3) nel profilo del serbatoio.

### Refitting the LH cowling structure

Position LH cowling structure (D) by inserting it into pin (D7) of the radiator through slot (D8).

Allow passage of wiring (D6) through slot (D9).

Secure no.2 hooks (D4) to slots (D5).

Insert no.2 table (D3) in tank profile.

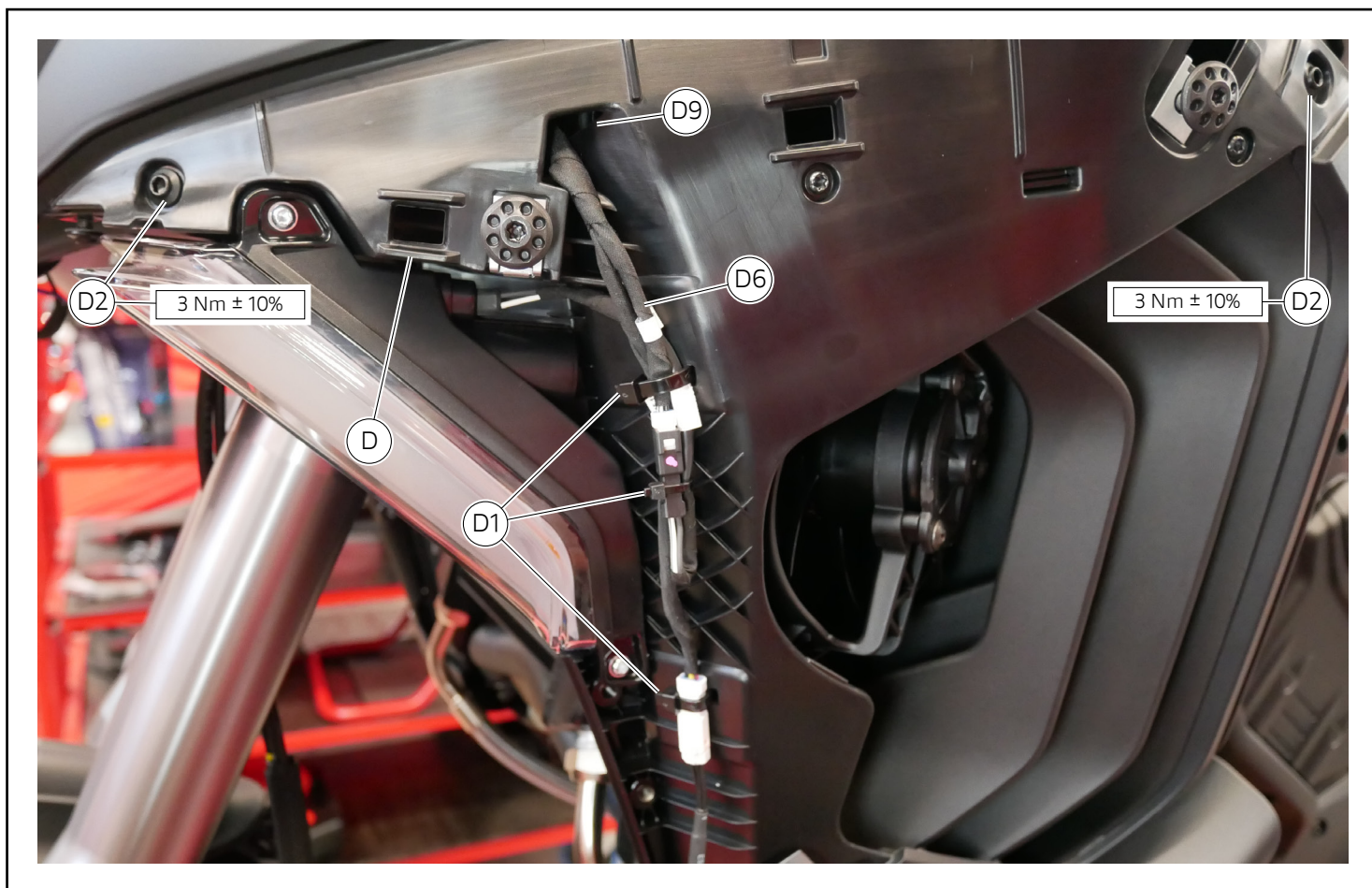

Serrare le n.2 viti (D2) alla coppia indicata. Fermare il cablaggio (D6) con n.3 fascette in nylon nuove (D1).

Tighten the no.2 screws (D2) to the specified torque. Secure wiring (D6) with no.3 new nylon ties (D1).



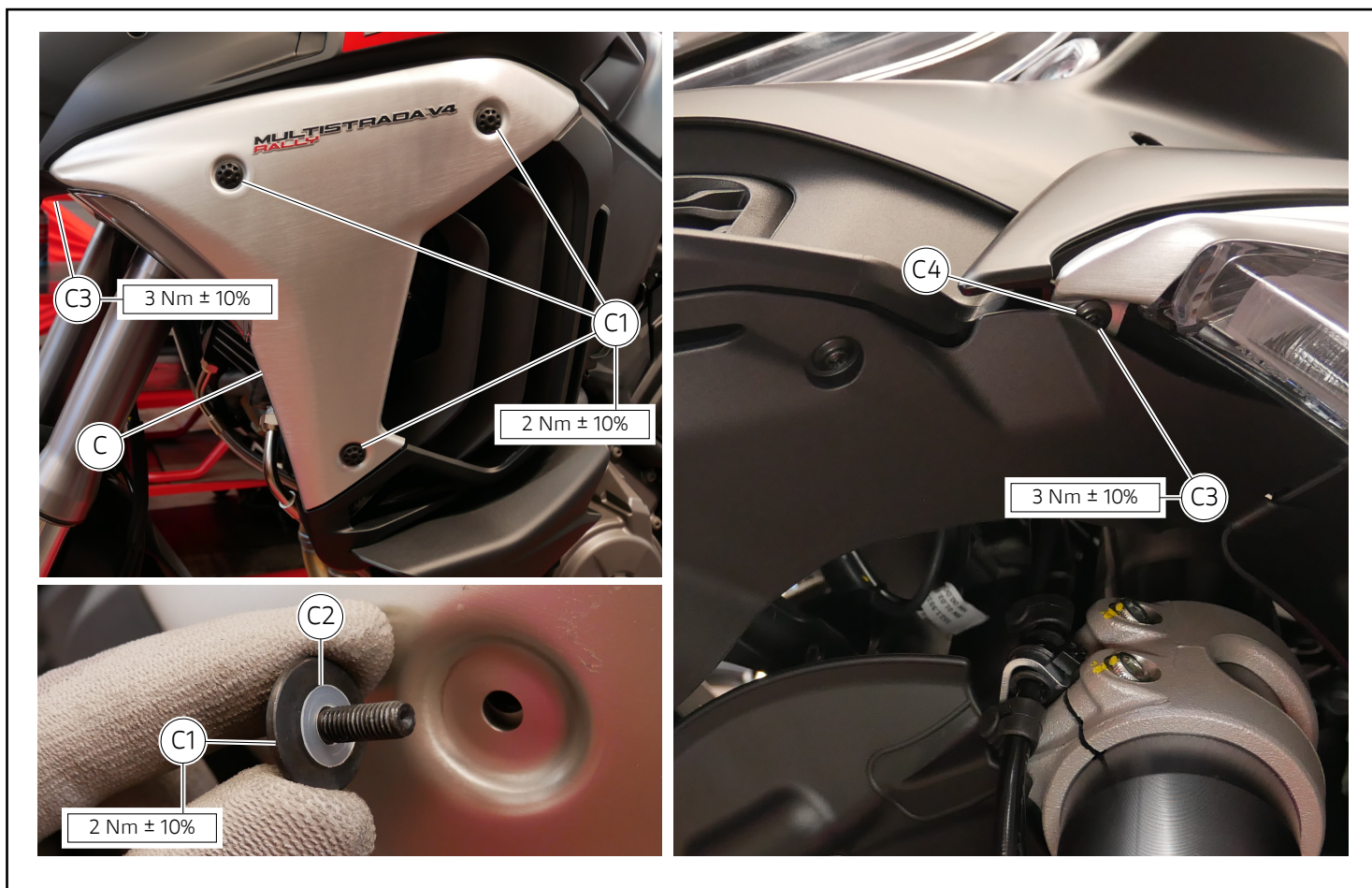

### Montaggio ala sinistra

Posizionare la carena sinistra (C). Fissare la carena (C) serrando le n.3 viti (C1) alla coppia indicata, dopo aver posizionato inferiormente le relative n.3 rosette (C2). Serrare la n.1 vite (C3) alla coppia indicata, dopo aver posizionato inferiormente la n.1 rosetta (C4).

### LH side cowling assembly

Position the LH fairing (C). Secure the fairing (C) by no.3 screws (C1) to the specified torque, after positioning the relevant no.3 washers (C2) below. Tighten no.1 screw (C3) to the specified torque, after positioning the relevant no.1 washer (C4) below.

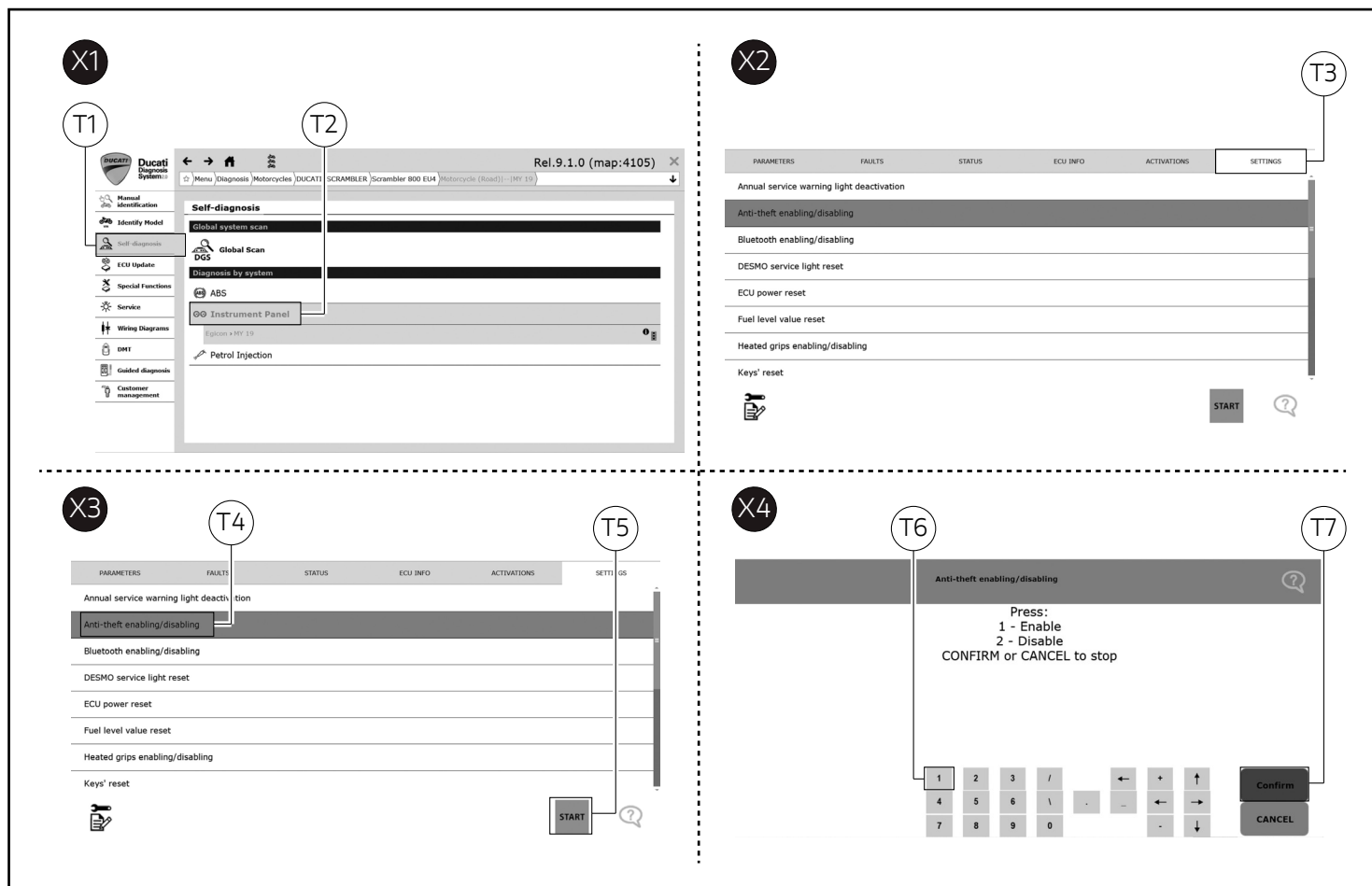

### Attivazione/Disattivazione antifurto

Collegare lo strumento di diagnosi al connettore acquisizione dati. Selezionare il modello corretto di motoveicolo. Selezionare l'ambiente "Self-diagnosis" (T1) nel menù a sinistra e successivamente il comando "Instrument Panel" (T2), come indicato in figura (X1). Selezionare l'ambiente "Settings" (T3) nel menù in alto, come indicato in figura (X2). Selezionare la funzione "Anti-theft enabling/disabling" (T4) e successivamente "Start" (T5), come indicato in figura (X3). Premere sulla tastiera del PC il numero "1" Enable" (T6) e successivamente il comando "Confirm" per abilitare la presenza dell'antifurto, come indicato in figura (X4).

### Attivazione/Disattivazione bluetooth

Collegare lo strumento di diagnosi al connettore acquisizione dati presente sul motoveicolo. Avviare il software di diagnosi sul PC. Recarsi nella sezione "Autodiagnosi" della centralina BBS e nella pagina "Regolazioni" è disponibile la funzione "Abilitazione/Disabilitazione presenza Bluetooth".

### Anti-theft system enabling/disabling

Connect the diagnostic tool to the data acquisition socket. Select the correct motorcycle model. Select "Self-diagnosis" (T1) from the menu on the left and then "Instrument Panel" (T2), as shown in figure (X1). Select "Settings" (T3) from the menu at the top, as shown in figure (X2). Select the "Anti-theft enabling/disabling" function (T4) and then "Start" (T5), as shown in figure (X3). Press number "1" Enable" (T6) on PC keyboard and then "Confirm" to enable the anti-theft system, as shown in figure (X4).

### Enabling/disabling the bluetooth

Connect the diagnosis instrument to the data acquisition socket present on motorcycle. Start the diagnosis software on the PC. Go to the "Self-Diagnosis" section of the BBS control unit, the "Enabling/Disabling the Bluetooth" function is available in the "Settings" page.

# レース専用部品 ご注文書

## ご注文商品

1	P/N	商品名
2	P/N	商品名
3	P/N	商品名
4	P/N	商品名
5	P/N	商品名

## お客様ご記入欄

私は上記レース専用部品を下記車両に装着し、サーキット走行のみに利用し、一般公道には利用しません。

車台番号 ZDM モデル名

お客様署名 ご注文日

## ドウカティ正規ネットワーク店記入欄

お客様に上記レース専用部品を販売し、レース専用部品のご利用方法を説明いたしました。

販売店署名 販売日 年 月 日

販売店様へお願い

- 上記ご記入の上、弊社アフターセールス部までFAXしてください。FAX : 03 - 6692 - 1317
- 取り付け車両 1台に 1枚でご使用ください。

Set montaggio antifurto / Anti-theft system assembly set / Jeu pose antivol / Montageset Diebstahlsicherung / Conjunto para a montagem do dispositivo antirroubo / 防盗系统安装套装 / Set montaje antirroubo / 盗難防止装置取り付けセット - 96681361AA

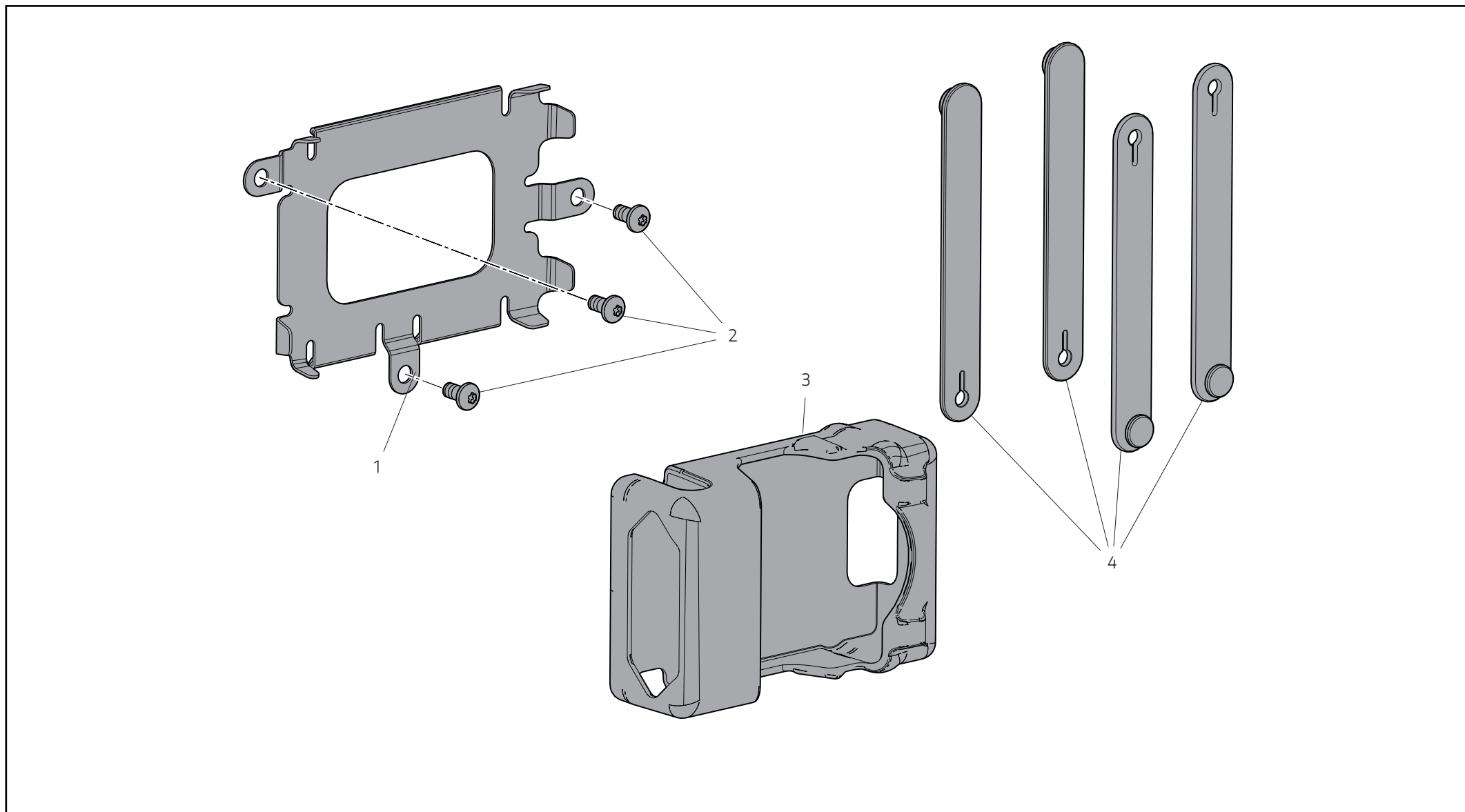

Pos.	Cod.	Nome	Name	Nom	Name	Nome	名称	Nombre	名称	Q.ty
1	97612821A	Staffa	Bracket	Bride	Bügel	Braçadeira	托架	Sostén	ブラケット	1
2	77440141A	Vite AF D4x8	Self-tapping screw D4x8	Vis auto-taraudeuse D4x8	Selbstschneidende Schraube D4x8	Parafuso autorroscante D4x8	AF 螺钉 D4x8	Tornillo AF D4x8	スクリュー AF D4x8	3
3	96610521A	Tampone supporto antifurto	Anti-theft system support buffer	Tampon support antivol	Abstützpuffer für Diebstahlsicherung	Tampão do suporte do dispositivo antirroubo	防盗系统支架缓冲垫	Tope soporte antirrobo	盗難防止装置サポートパッド	1
4	74110131A	Fascetta in gomma L=82 mm	Rubber tie L=82 mm	Collier en caoutchouc L=82 mm	Gummischelle L=82 mm	Braçadeira de borracha de 82 mm de comprimento	橡胶扎带 L=82 mm	Abrazadera de goma L=82 mm	ゴム製クランプ L=82 mm	4